

SA-8100

KCW
KUW
FVW
PIONEER

SA-8100

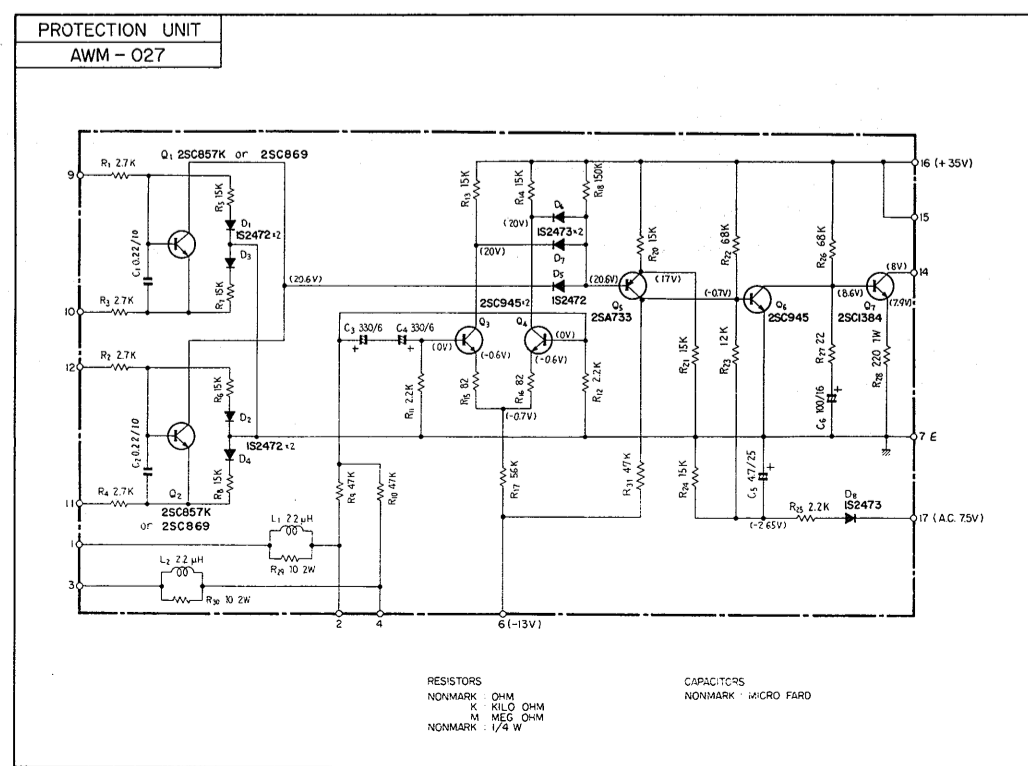

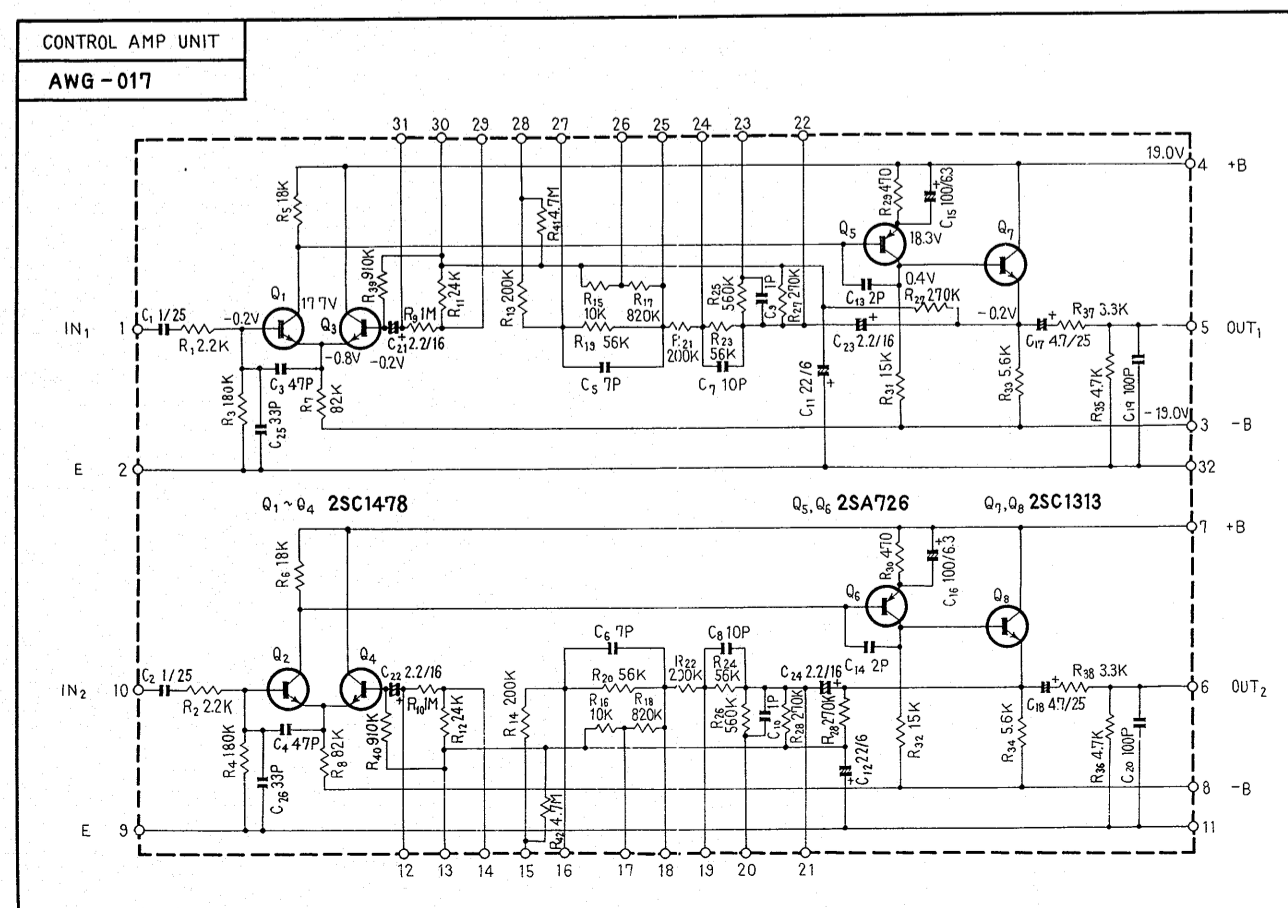
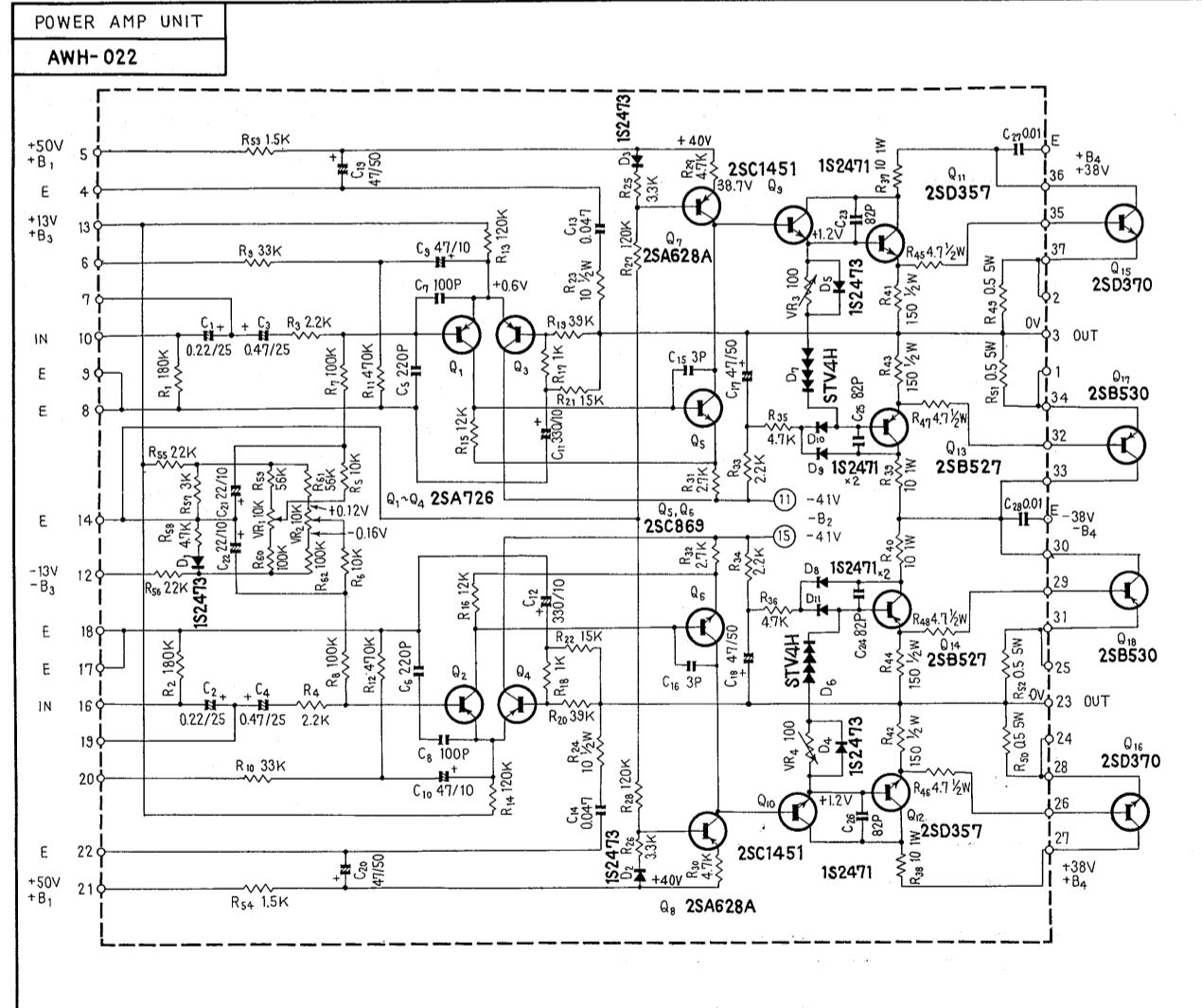
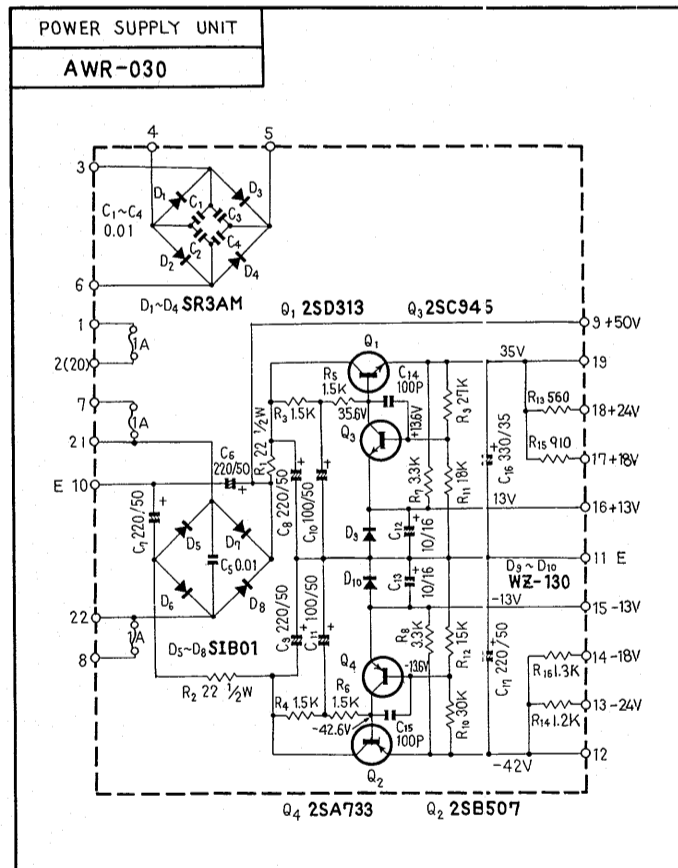
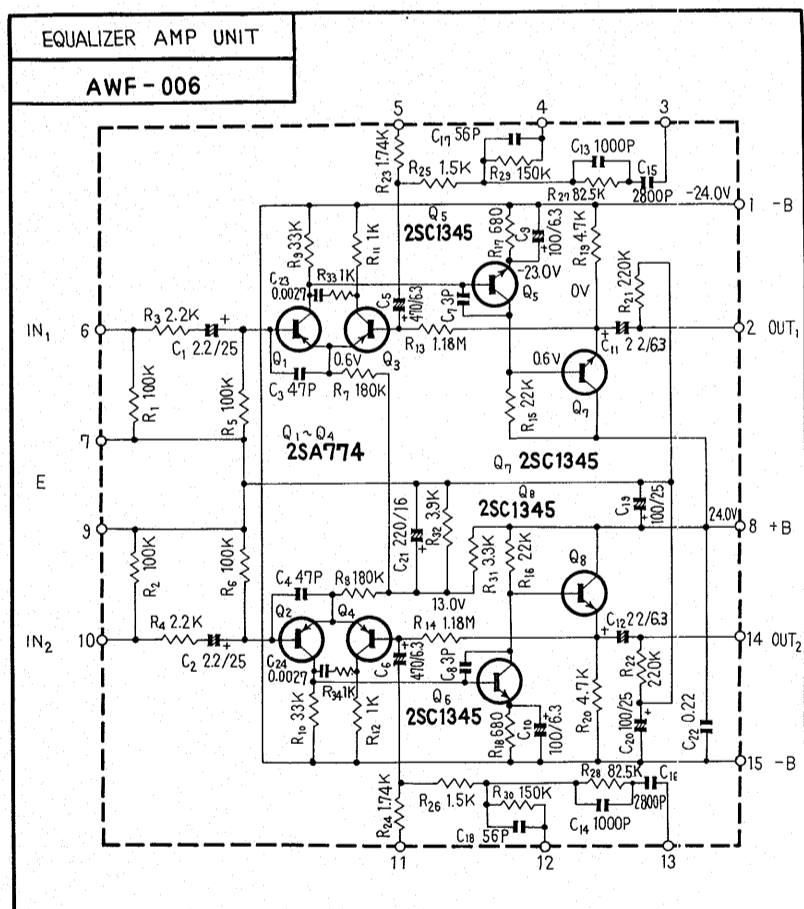
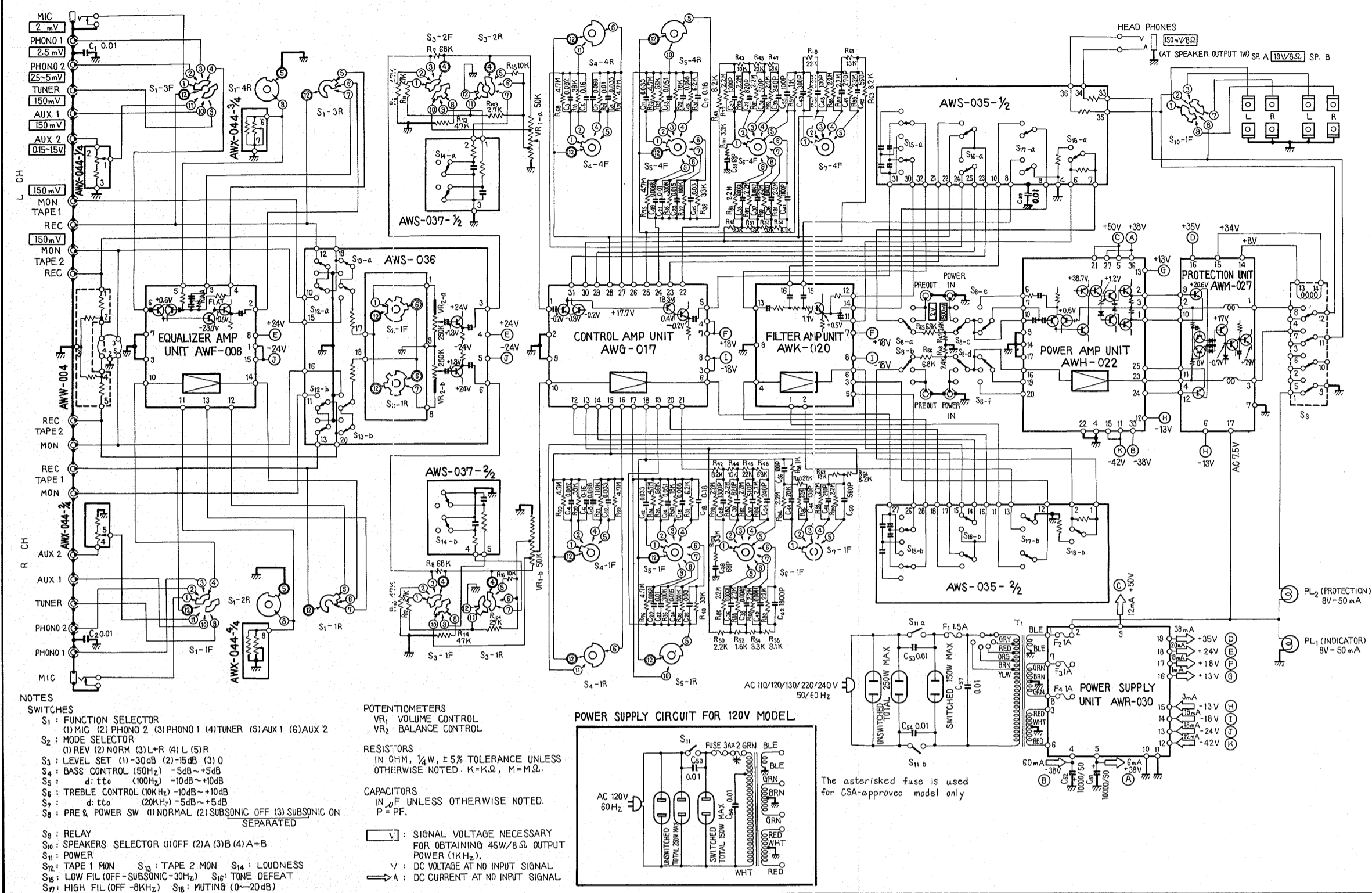
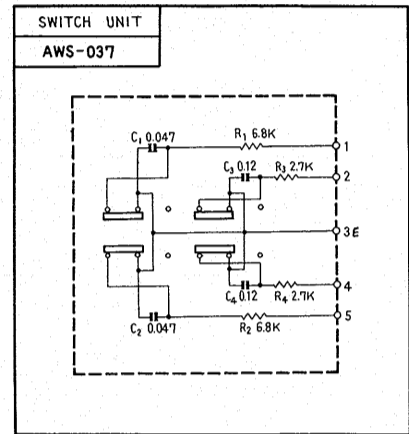
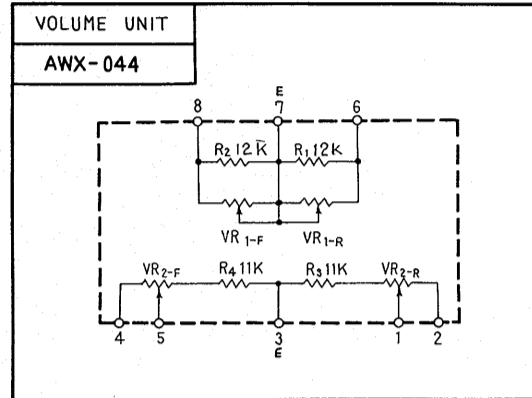
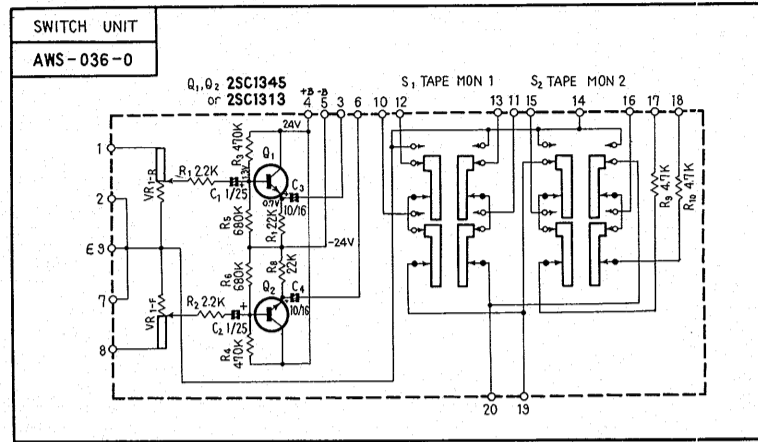
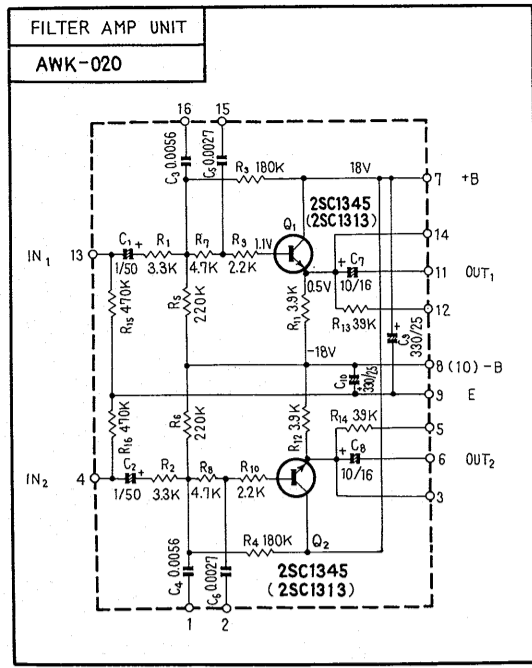
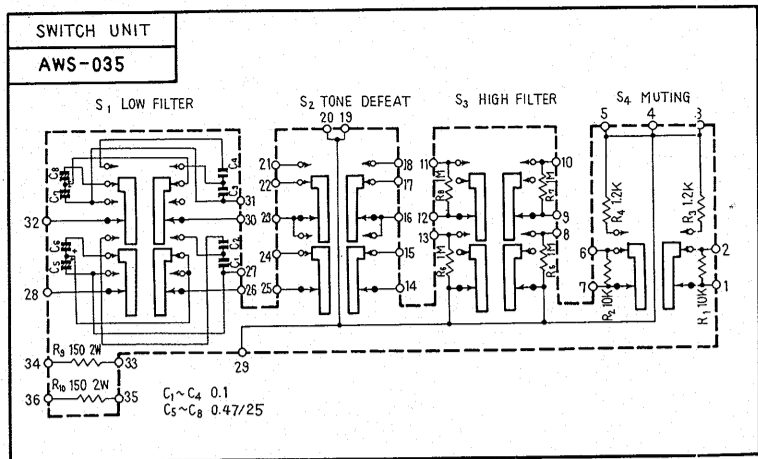

2SB530 2SD370		2SC1384	
2SA726 2SC869 2SC1313		2SB507 2SD313	
2SC857		2SA733	
2SC1345		2SA628A	
2SC1451		2SB527 2SD357	
2SC945		2SA774 2SC1478	

MOUNTING TEMPLATE

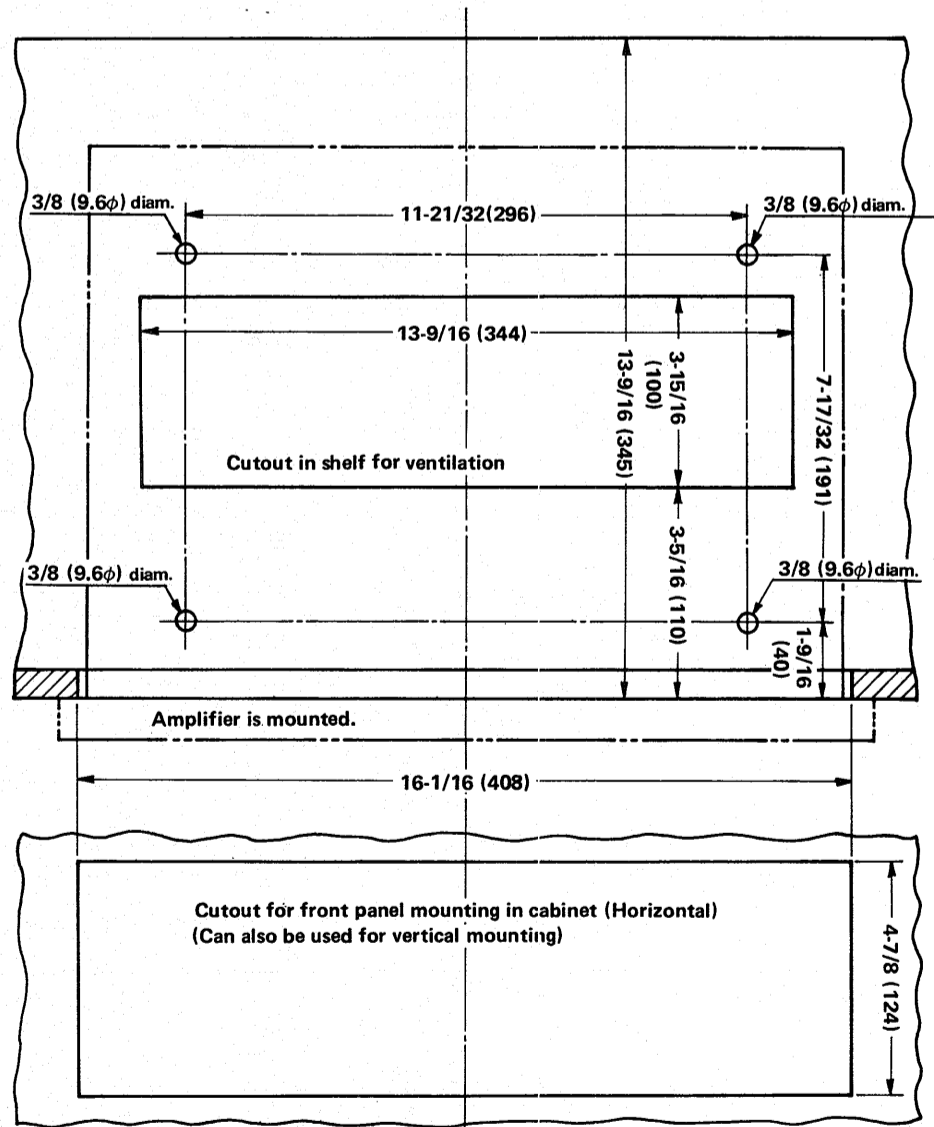

Remove the four feet on the bottom plate of the unit.
After removing feet, fasten setscrews into holes from which feet were removed.

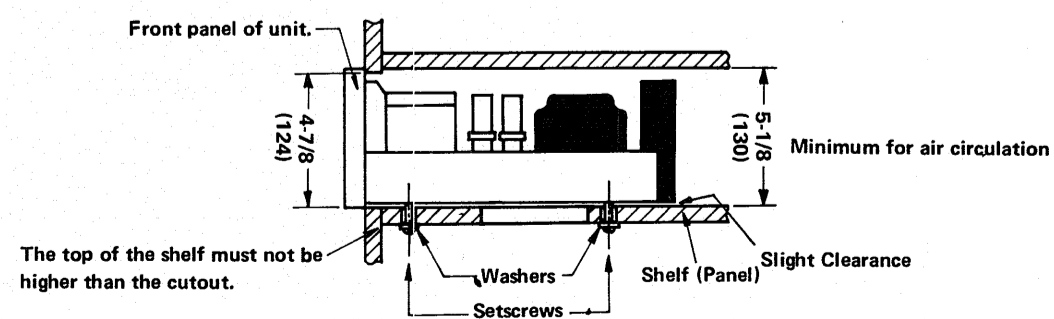

Use M4 (ISO) setscrews of within 1/3 (10mm) long for combining amp's bottom plate with any panel, allowing a slight clearance.