

SA-9100

KUW
FWV
PIONEER

SA-9100

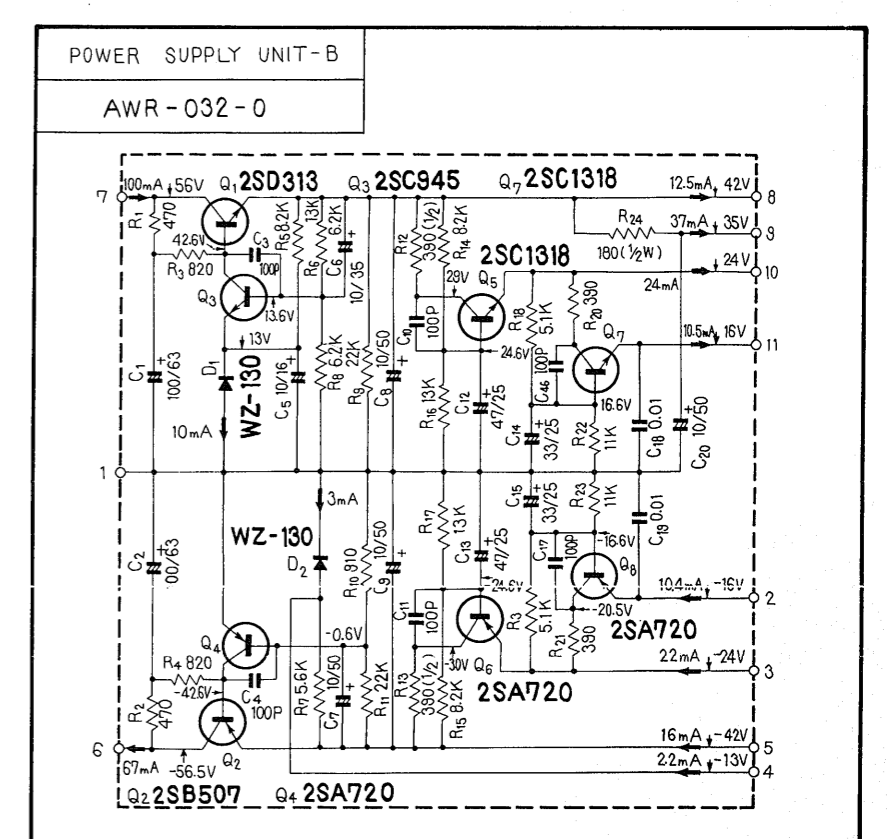

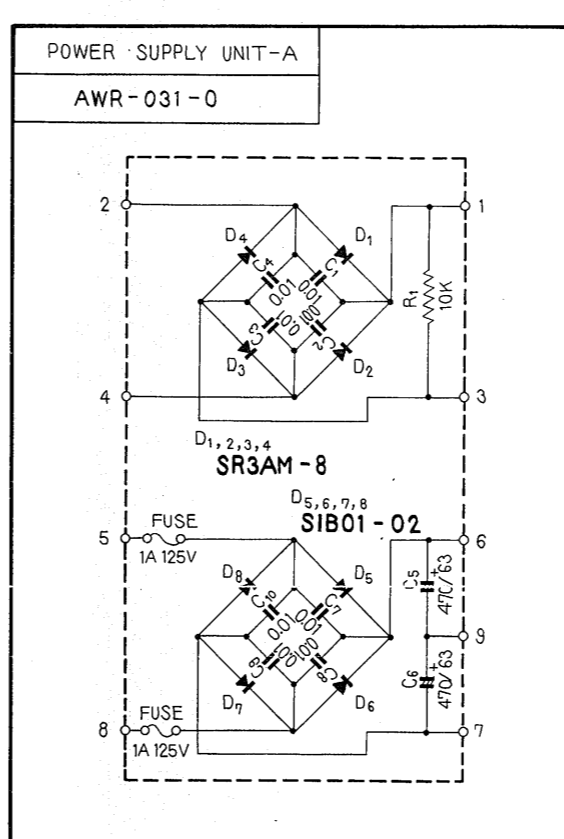
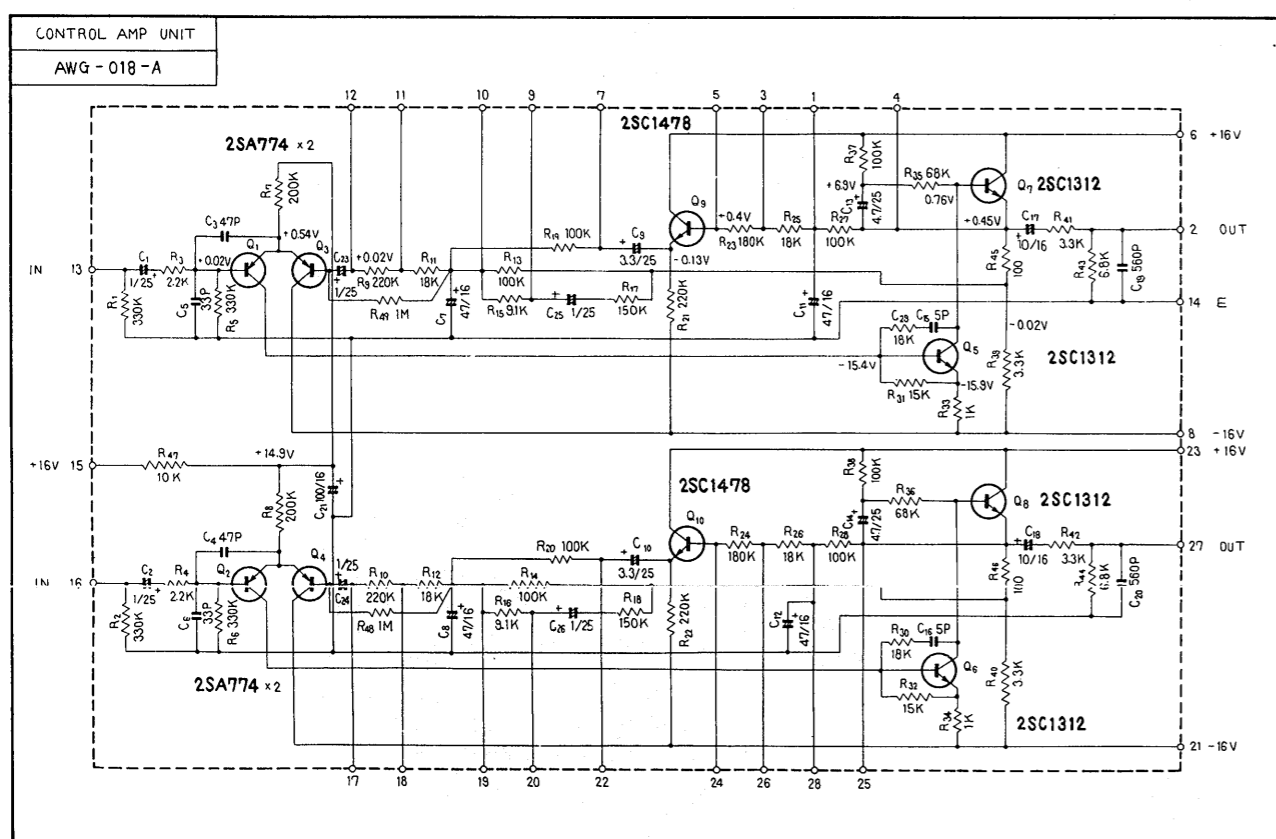
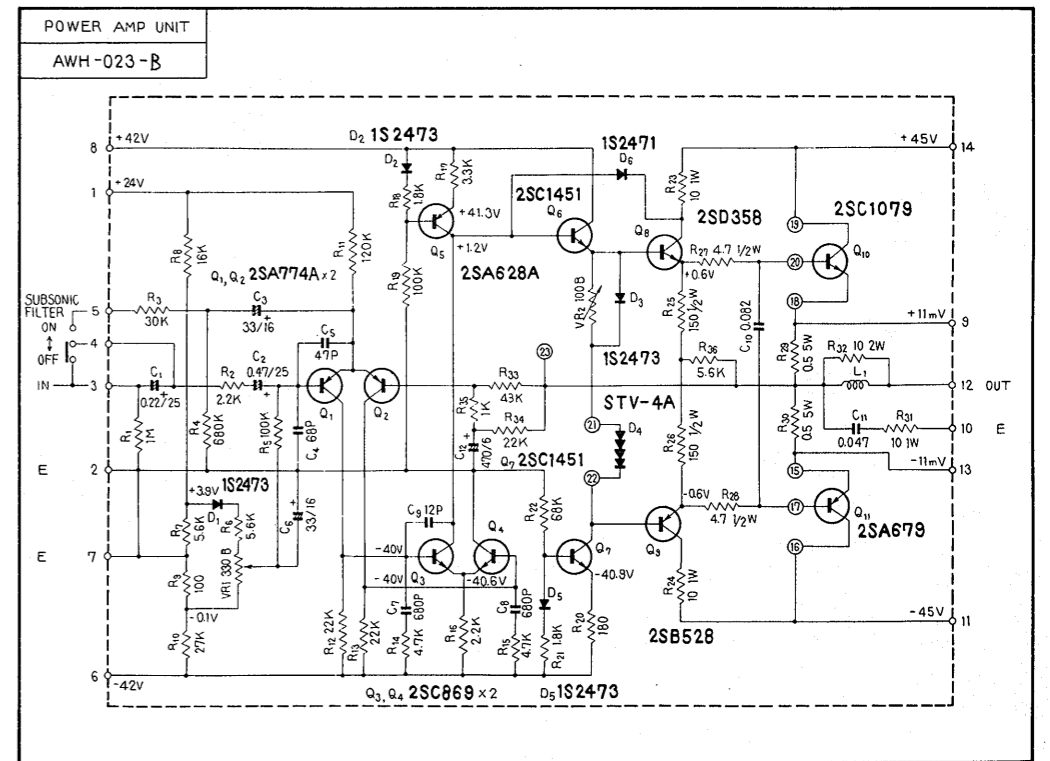
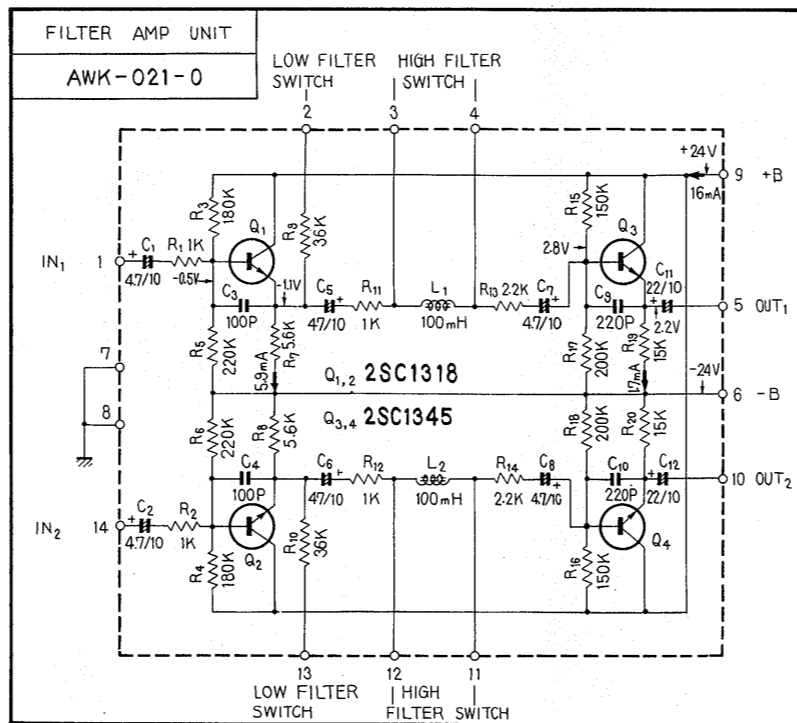
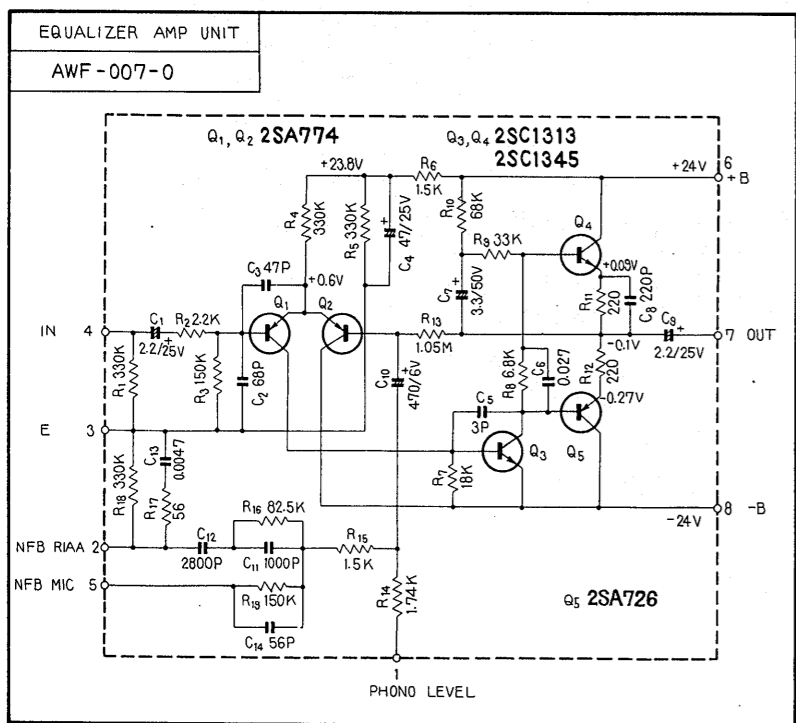
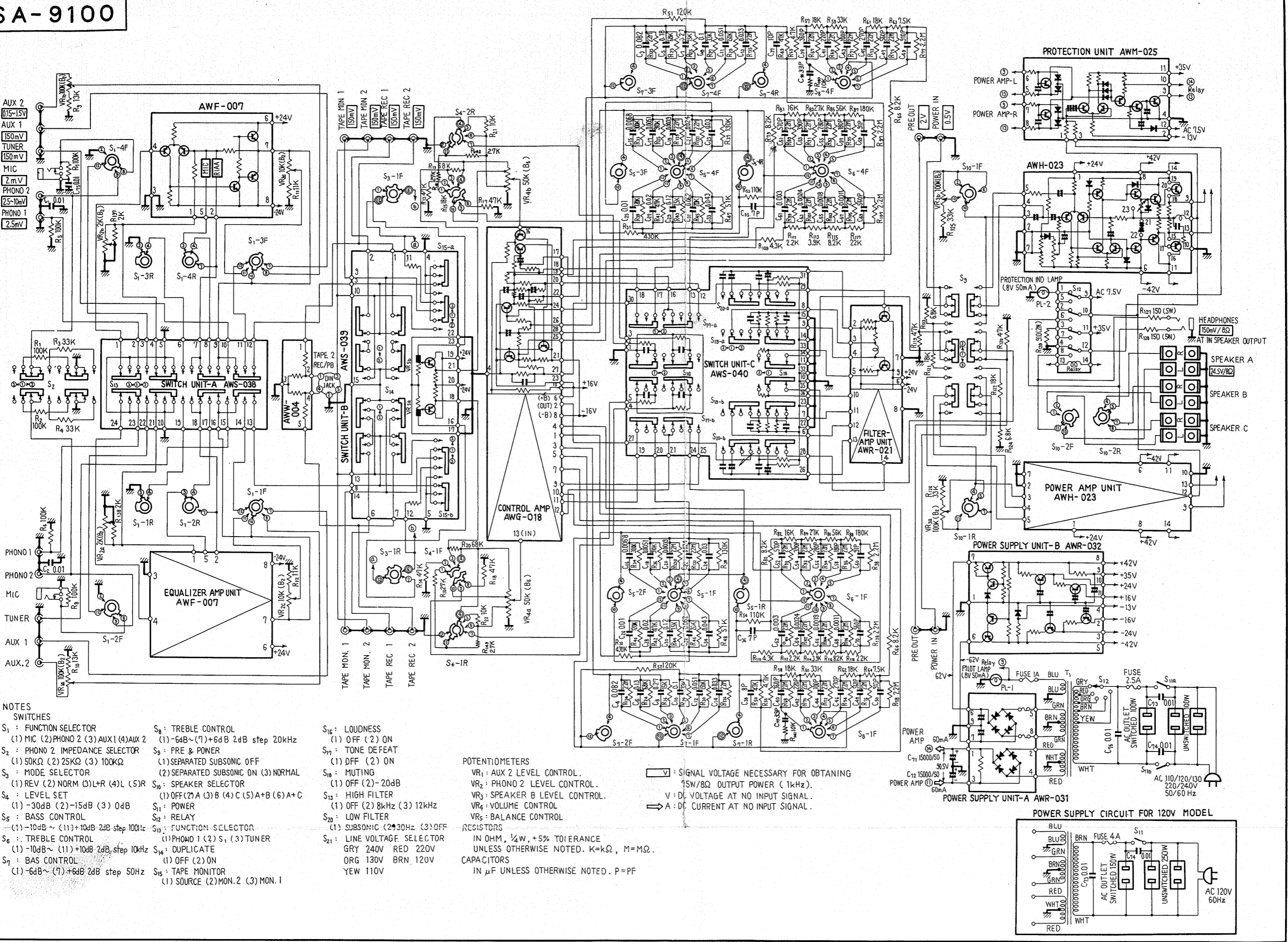
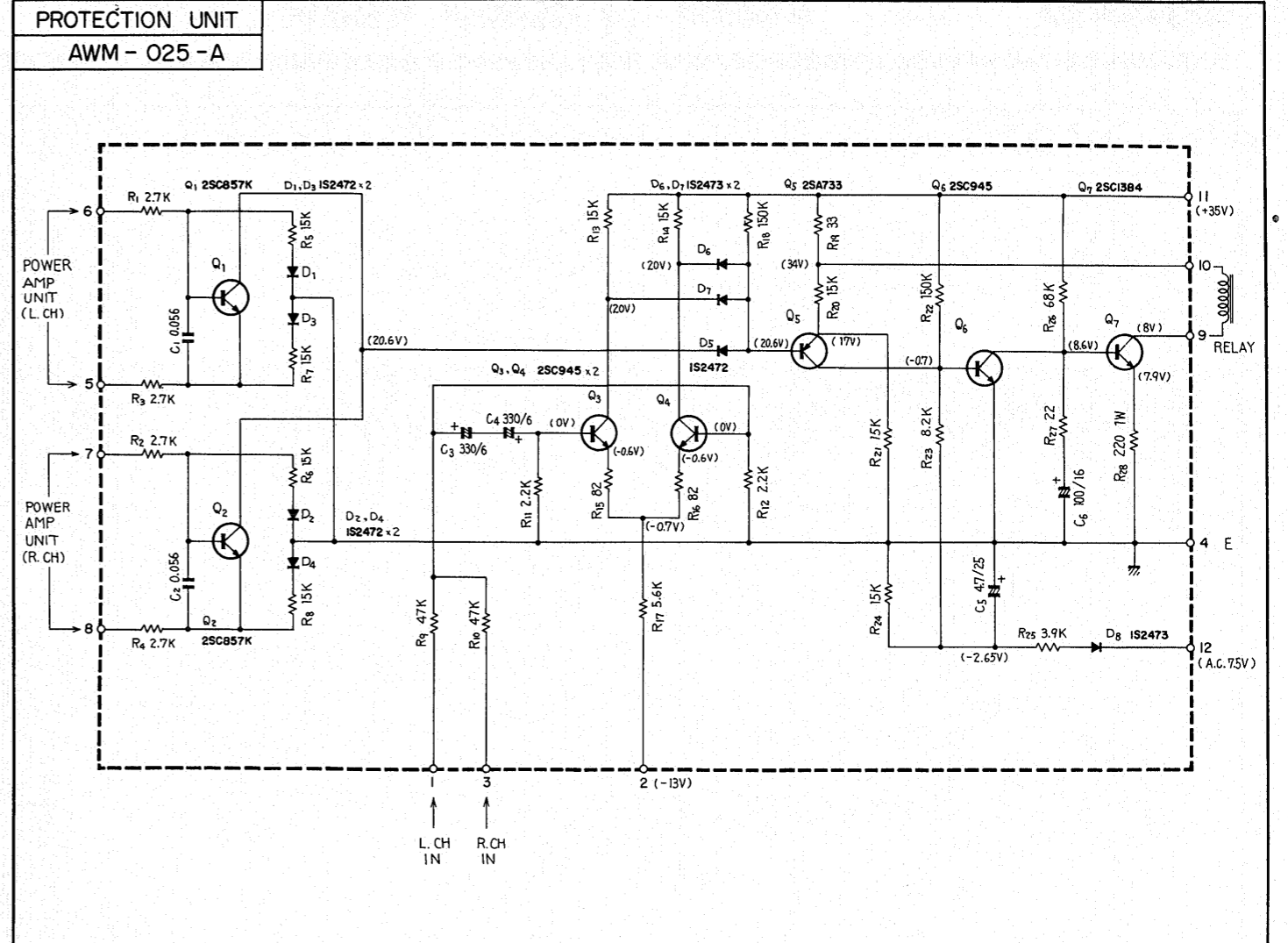
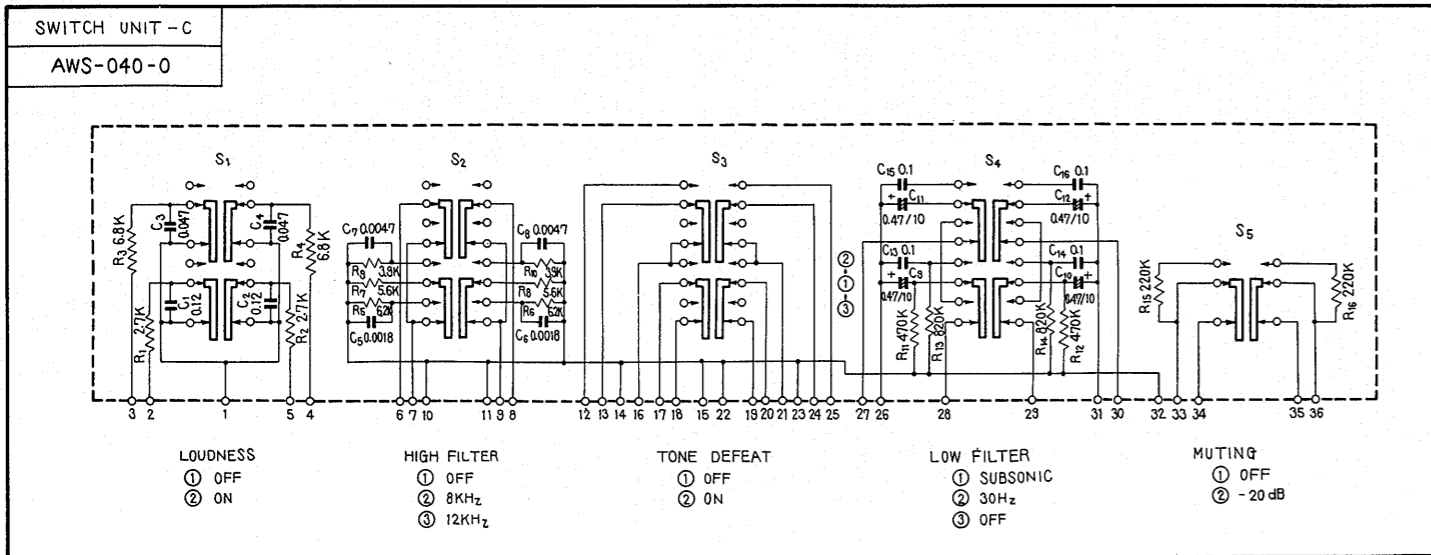
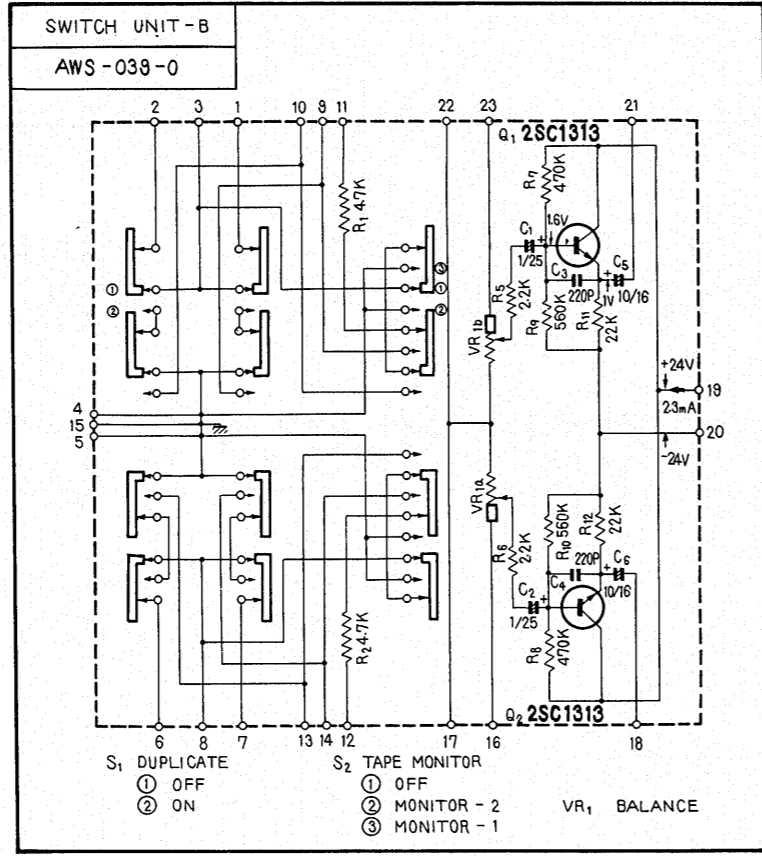
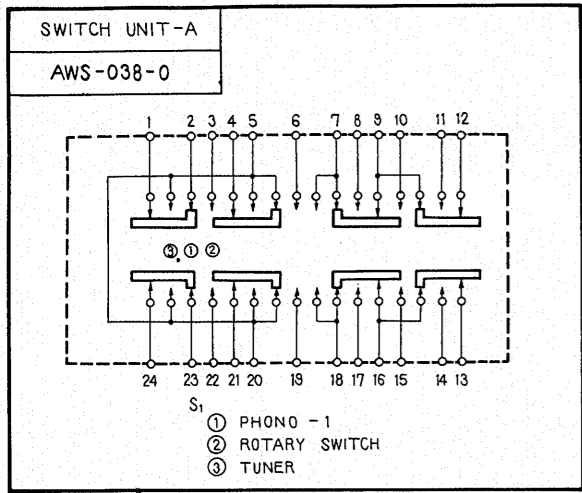

2SA628A 2SA720R 2SC1318		2SA679 2SC1079	
2SA733		2SA774 2SA774A 2SC1478	
2SA726 2SC869 2SC1313 2SC1312		2SB507 2SD313	
2SB528 2SD358		2SC857K	
2SC945		2SC1345	
2SC1384		2SC1451	

MOUNTING TEMPLATE

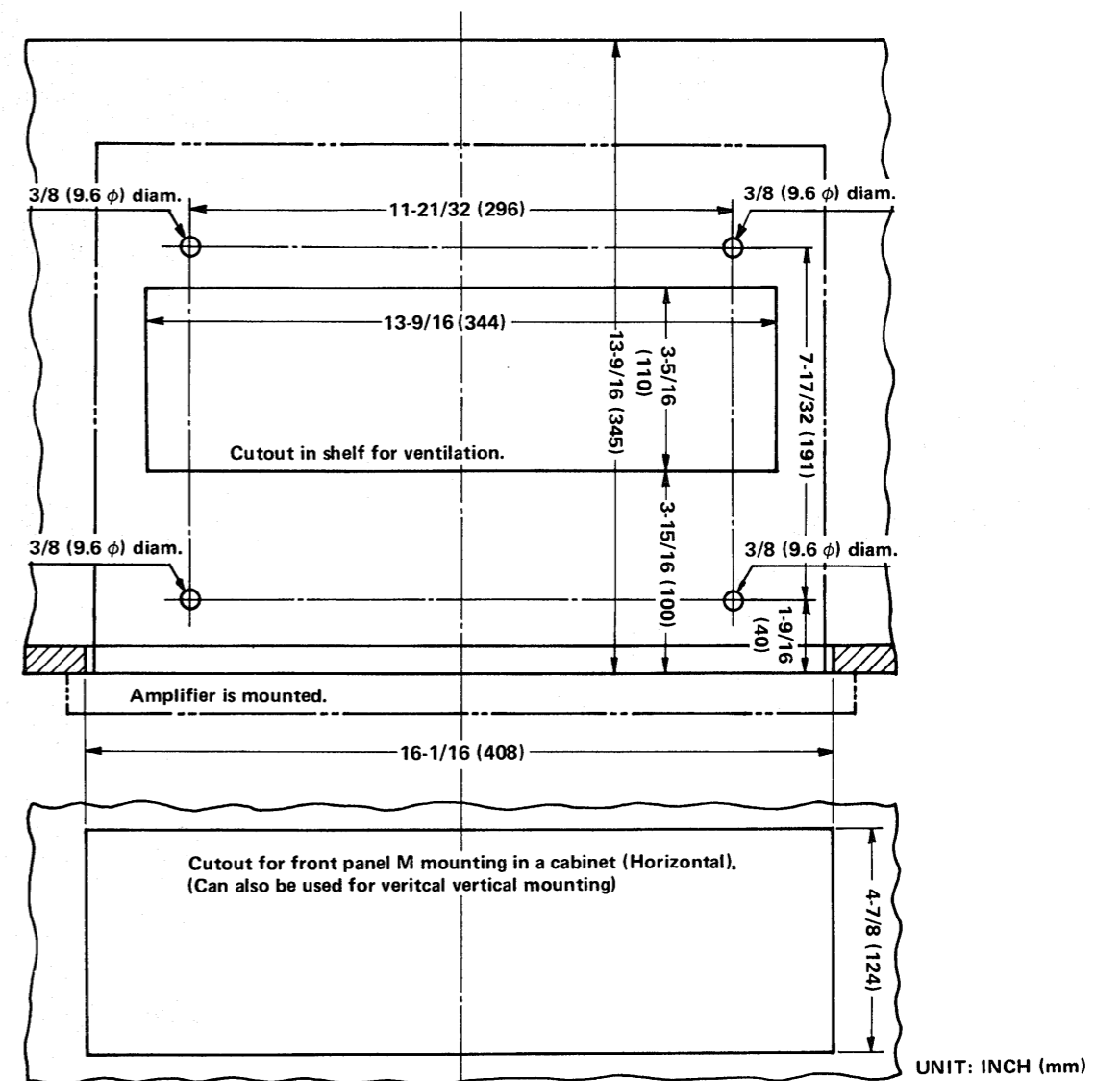

Remove the four feet on the bottom plate of the unit.
After removing feet, fasten setscrews into holes from which feet were removed.

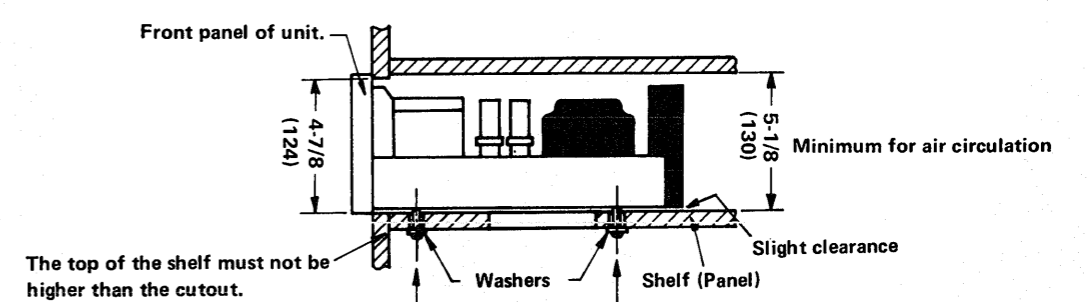

Use M4 (ISO) setscrews of within 1/3 (10mm) in. long for combining amp's bottom plate with any panel, allowing a slight clearance.